

HYBRID STEPPING MOTORS HY / HS / HN Series

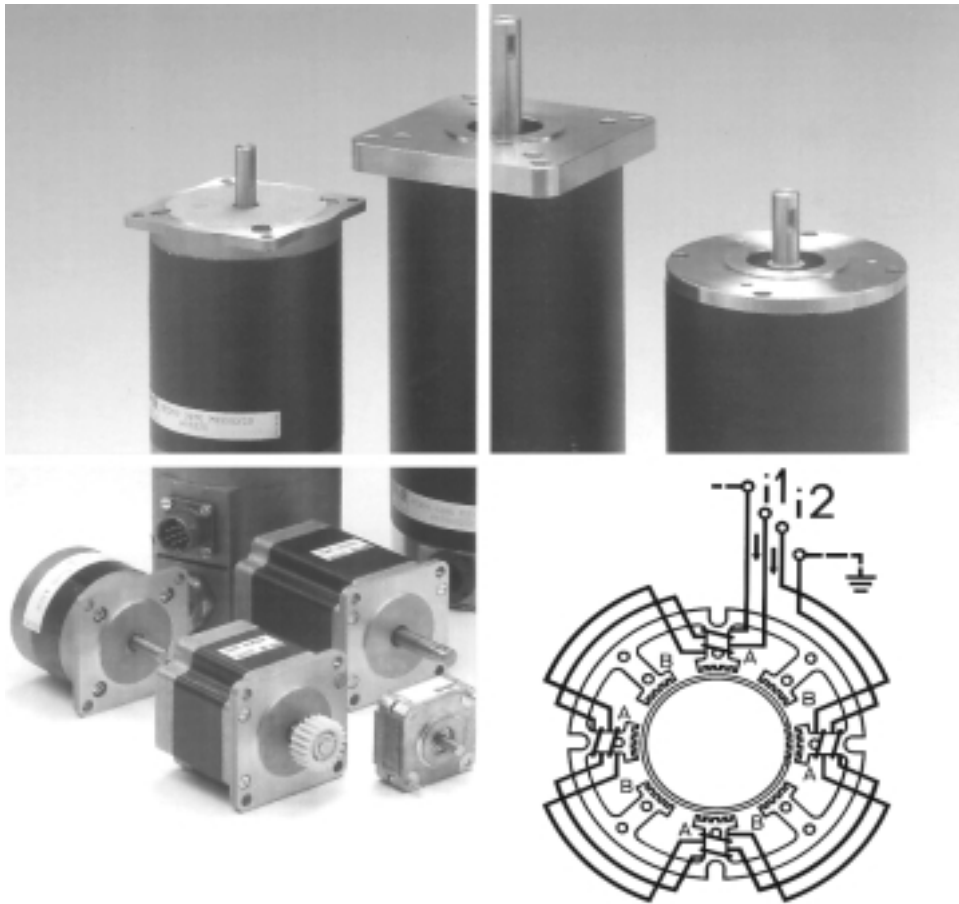

- Long Life
- Compact Design
- Bipolar / Unipolar Models

- Holding Torque up to 1425 Ncm
- High Performances Series HS and HN
- Several Options available (Encoders, Gearboxes, Cables, etc.)

The most important applications markets are:

- peripherals
- office automation
- telecommunication
- reprographic and printing machines
- tools machines
- industrial automation
- machines for wood working
- car instruments and servo controls
- sewing machines
- machines for textile and clothes sectors (knitting, shoe)
- machines for farm and food industries
- machines for packing and wrapping
- laboratory, measuring, electromedical instruments
- spot lights for amusement

STEPPING MOTORS DESCRIPTION KEY

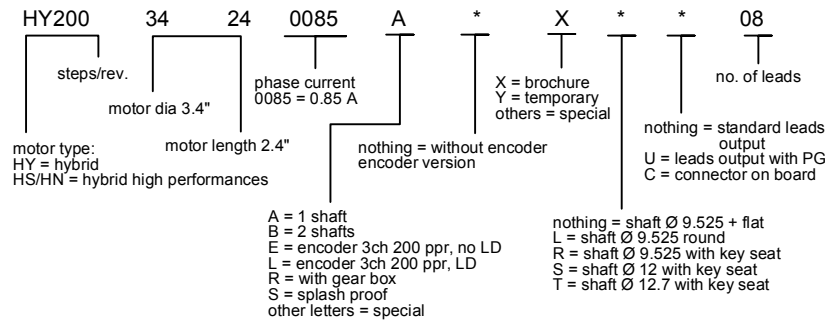

Shaft extensions

All motors can be supplied with single or double ended shaft, as per customer's request.

Rotation

Stepping motors can run clockwise or counterclockwise, depending the commutation.

Insulation class: B

Operating temperature

Ambient operation temperature: -20° C to +40° C.

Number of leads

Standard stepping motors have 8 leads to be driven in bipolar or unipolar. If requested, motors with 4 or 6 leads can also be supplied.

Angular accuracy

Standard ±5%, upon request ±3%.

Angular accuracy is defined as the deviation from a theoretical position, in percentage of one step, after any number of steps.

Holding torque

The values of holding torque of the different models are indicated in the data sheets. Holding torque is measured with two phases supplied at the rated current

Specifications and approvals

The motors manufactured according to EN 60034-1: 1995-02. The motors with drive voltage higher than or equal to 120 V are suitable to be fitted on machines equipped with additional insulation, or, when the motor itself has the grounding, through its clamping screws. Due to their peculiarity the stepping motors can't be always used at a continuous running at any speed. Should the motor be opened or tampered, its performances are no more guaranteed.



THE TECHNICAL SPECIFICATIONS MENTIONED IN THIS CATALOGUE ARE TYPICAL

The stepping motor is an electromechanical transducer that converts electrical pulses into programmable mechanical movements: it is both an actuator and a positioning device and it is driven by electronic drives. Stepping motors are divided into three different categories: **Variable Reluctance Motors**,

Permanent Magnet Motors and Hybrid Motors they perform high torque, accuracy and speed.

Stepping motors, with some changes, can also be connected to the network and work as synchronous motors, as listed in AC synchronous motors catalogue. Stepping motors are very rugged and do not require maintenance as they have neither brushes and nor collector.

HYBRID MOTORS

HOLDING TORQUE

	UNIPOLAR (Ncm)	BIPOLAR (Ncm)
HY 100 1613	9	11÷13
HY 200 1607		8,7
HY 200 1713	11,2	13÷23,4
HY 200 1717		23,1÷24,6
HY 200 2215	25÷27	31÷34
HY 200 2220	52÷53	64÷69
HY 200 2226	87÷89	109÷114
HY 200 2240	111÷113	145÷148
HS 200 2216	37	47

HYBRID MOTORS

HOLDING TORQUE

	UNIPOLAR (Ncm)	BIPOLAR (Ncm)
HS 200 2221	75	98
HS 200 2231	125	161÷163
HY 200 3424	116÷150	150÷193
HN 200 3426	230	280
HN 200 3438	380	480
HN 200 3451	620	760
HY 200 4247	377÷388	580÷597
HY 200 4266/4270	798÷830	990÷1270
HY 200 4288	1140	1425

NEW High Performances Stepping Motors HS and HN series

Its main feature is the torque / inertia ratio which places the product among the best ones available on the market.

Indeed, thanks to a choice of new Neodymium magnetic material and internal mechanical geometry, it has been possible to obtain stepping motors that with identical overall dimensions deliver 100% higher torque compared to those built to the prior technology.

Of particular interest is to underline that HS and HN series stepping motors deliver their own characteristics with extremely low values of voltage and current ratings.

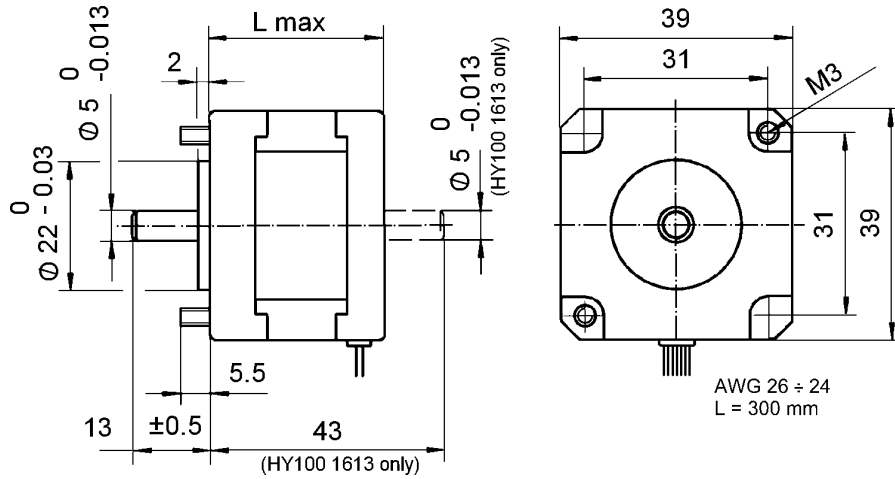

Specifications

	HY100 1613				HY200 1607
	0050 BX08	0075 AX04	0160 BX04	0095 BX04	0060 AX04
step angle	3,6°	3,6°	3,6°	3,6°	1,8°
step angle accuracy	5	5	5	5	5
rated phase current	0,5	0,75	1,6	0,95	0,6
phase resistance	7,2	4,4	1,2	4,9	6,6
phase inductance	5,8	5,6	1,4	5,1	8,5
holding torque unipolar *	Ncm	-	-	-	-
holding torque bipolar *	Ncm	11,5	12	13**	8,7
detent torque	Ncm	1,6	1,6	1,6	1,0
rotor inertia	g cm ²	16	16	16	11
mass	Kg	0,2	0,2	0,2	0,15
max. length	mm	34,0	34,0	34,0	20,5
insulation class		B	B	B	B

* two phases "ON"

** torque with duty cycle < 50%

HY100 1613 0050 BX08

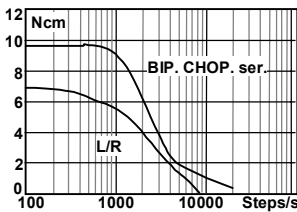

DRIVE: BIP.CHOP., SER., 36 V - 0.35 A/PH
DRIVE: UNIP.CHOP., L/R, 36 V - RS = 61 OHM

HY100 1613 0075 AX04

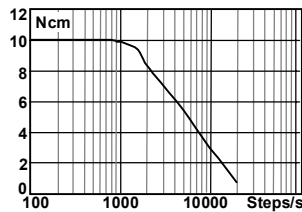

DRIVE: BIP.CHOP., 36 V - 0.75 A/PH

HY200 1607 0060 AX04

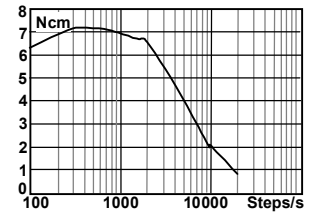

DRIVE: BIP.CHOP., 36 V - 0.6 A/PH

HY100 1613 0095 BX04

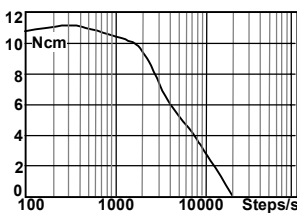

DRIVE: BIP.CHOP., 36 V - 0.95 A/PH

HY100 1613 0160 BX04

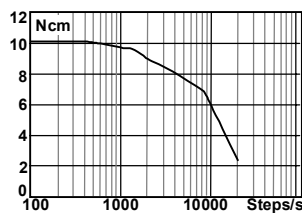

DRIVE: BIP.CHOP., 36 V - 1.6 A/PH

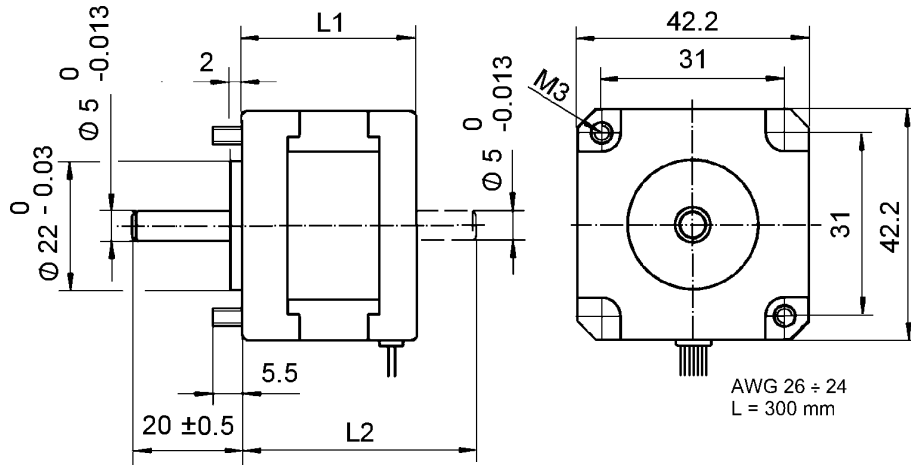

Specifications	HY200 1713				HY200 1717	HY200 1718	
	0040 BX06	0033 BX04	0150 AX04	0100 BS04***	0100 BC04	0090 BX04	0230 BX04
step angle	1,8°	1,8°	1,8°	1,8°	1,8°	1,8°	1,8°
step angle accuracy	5	5	5	5	5	5	5
rated phase current	0,4	0,33	1,5	1,0	1,0	0,9	2,3
phase resistance	15,6	23,9	1,0	5,6	4,6	4,2	0,72
phase inductance	11,9	29,8	1,2	8,5	10,6	5,8	0,83
holding torque unipolar *	11,2	-	-	-	-	-	-
holding torque bipolar *	14,5	13,7	13,0	23,4**	23,1	29	29
detent torque	1,7	1,7	1,7	1,7	1,7	4,5	4,5
rotor inertia	18	18	18	18	32	36	36
mass	0,2	0,2	0,2	0,2	0,3	0,3	0,3
length 1	34	34	34	34	43	46	46
length 2	45	45	45	45	54	57	57
insulation class	B	B	B	B	B	B	B

* two phases "ON"
 ** torque with duty cycle < 50%
 *** special flange. see options page

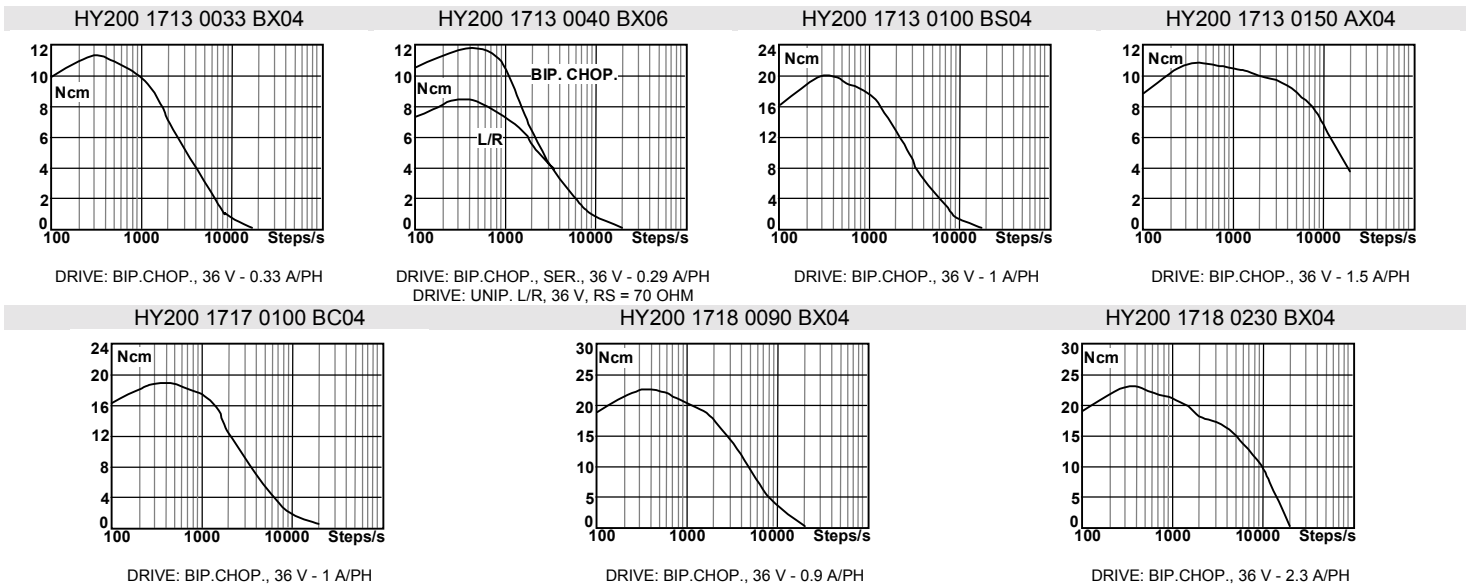

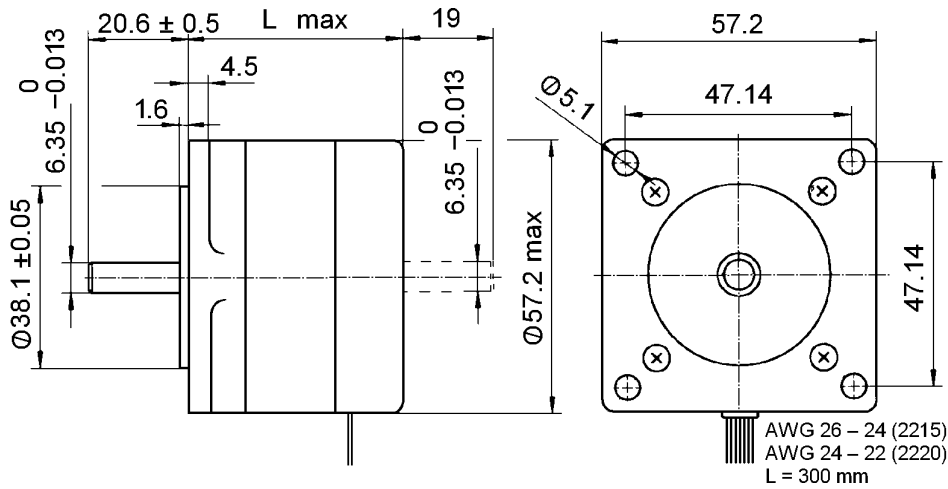
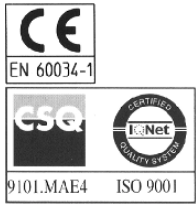

Specifications

	HY200 2215				HY200 2220		
	0150 AX08 0150 BX08	0100 AX08 0100 BX08	0033 AX04 0033 BX04	0220 AX04 0220 BX04	0044 AX08 0044 BX08	0100 AX08 0100 BX08	0210 AX08 0210 BX08
step angle	1,8°	1,8°	1,8°	1,8°	1,8°	1,8°	1,8°
step angle accuracy	5 %	5	5	5	5	5	5
rated phase current	1,5 A	1,0	0,33	2,2	0,44	1,0	2,1
phase resistance	1,5 Ω	3,4	33,8	0,7	23	5	1,1
phase inductance	1,5 mH	3,8	54,6	1,2	39,2	8	1,7
holding torque unipolar *	25 Ncm	27	-	-	52	53	52
holding torque bipolar *	33 Ncm	34	32	31	65	69	64
detent torque	3,4 Ncm	3,4	3,4	3,4	5,3	5,3	5,3
rotor inertia	56 g cm ²	56	56	56	124	124	124
mass	0,34 Kg	0,34	0,34	0,34	0,5	0,5	0,5
max. length	40 mm	40	40	40	52	52	52
max. applicable voltage	75 V	75	75	75	75	75	75
insulation class	B	B	B	B	B	B	B

* two phases "ON"

HY200 2215 0033 AX04

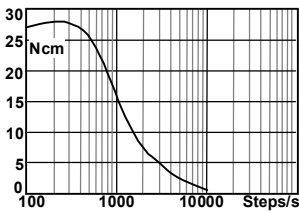

DRIVE: BIP.CHOP., 36 V - 0.33 A/PH

HY200 2215 0100 AX08

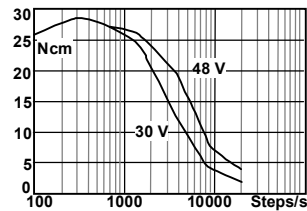

DRIVE: BIP.CHOP. PAR., 1.5 A/PH

HY200 2215 0150 AX08

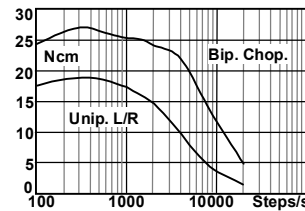

DRIVE: BIP.CHOP. PAR., 48 V - 2.2 A/PH
DRIVE: UNIP. L/R, 36 V, RS = 22 OHM

HY200 2215 0220 AX04

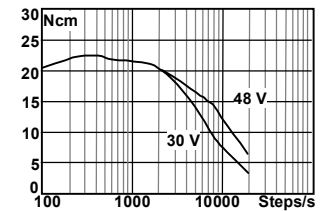

DRIVE: BIP.CHOP., 2.2 A/PH

HY200 2220 0044 AX08

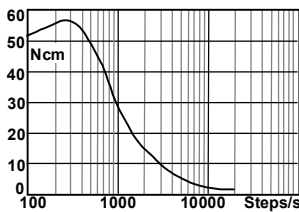

DRIVE: BIP.CHOP. PAR., 36 V - 0.62 A/PH

HY200 2220 0100 AX08

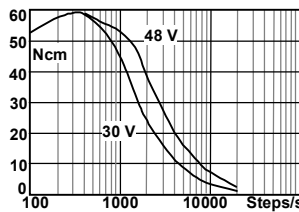

DRIVE: BIP.CHOP. PAR., 1.5 A/PH

HY200 2220 0210 AX08

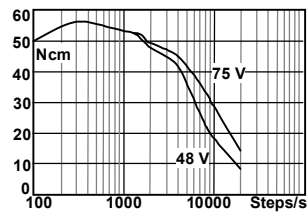

DRIVE: BIP.CHOP. PAR., 3 A/PH

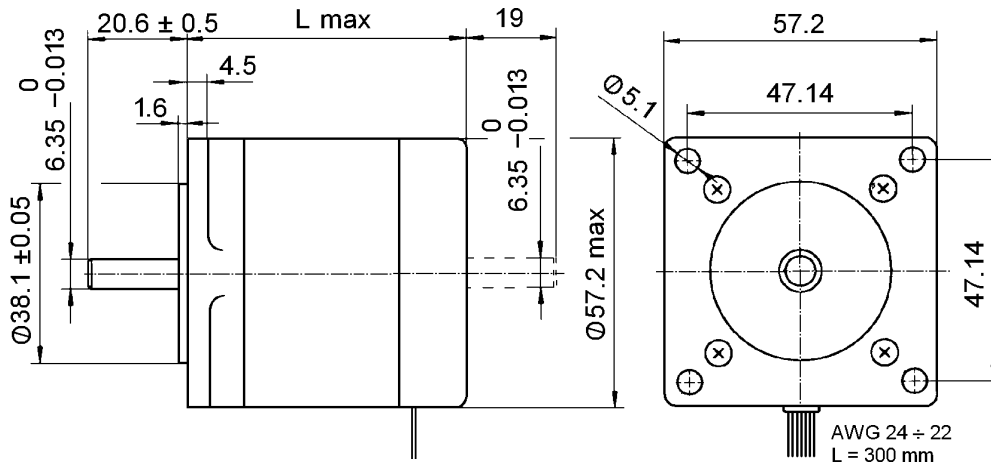
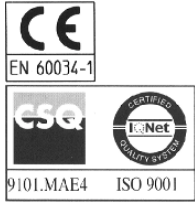

Specifications

	HY200 2226				HY200 2240	
	0160 AX08 0160 BX08	0190 AX08 0190 BX08	0250 AX04 0250 BX04	0470 AX08 0470 BX08	0290 AX08 0290 BX08	0460 AX08 0460 BX08
step angle	1,8°	1,8°	1,8°	1,8°	1,8°	1,8°
step angle accuracy	% 5	5	5	5	5	5
rated phase current	A 1,6	1,9	2,5	4,7	2,9	4,6
phase resistance	Ω 2,6	1,8	1,1	0,33	1,2	0,5
phase inductance	mH 4,7	3,3	4,0	0,5	2,4	0,9
holding torque unipolar *	Ncm 87	89	-	87	113	111
holding torque bipolar *	Ncm 109	113	114	109	148	145
detent torque	Ncm 8,5	8,5	8,5	8,5	10	10
rotor inertia	g cm ² 200	200	200	200	330	330
mass	Kg 0,7	0,7	0,7	0,7	1,2	1,2
max. length	mm 67	67	67	67	103	103
max. applicable voltage	V 75	75	75	75	75	75
insulation class	B	B	B	B	B	B

* two phases "ON"

HY200 2226 0160 AX08

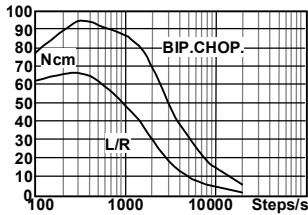

DRIVE: BIP.CHOP., PAR., 48 V - 2.3 A/PH
DRIVE: UNIP. L/R, 36 V, RS = 18 OHM

HY200 2226 0190 AX08

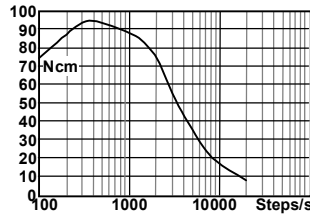

DRIVE: BIP.CHOP.PAR., 48 V - 2.7 A/PH

HY200 2226 0250 AX04

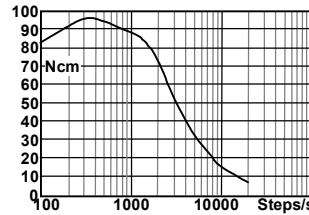

DRIVE: BIP.CHOP., 48 V - 2.5 A/PH

HY200 2226 0470 AX08

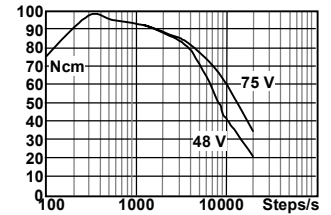

DRIVE: BIP.CHOP. PAR., 6.7 A/PH

HY200 2240 0290 AX08

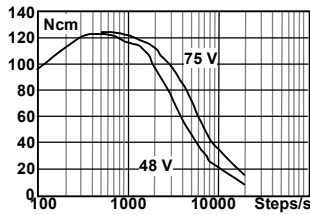

DRIVE: BIP.CHOP. PAR., 4.1 A/PH

HY200 2240 0460 AX08

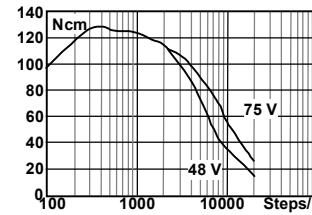

DRIVE: BIP.CHOP. PAR., 6.5 A/PH

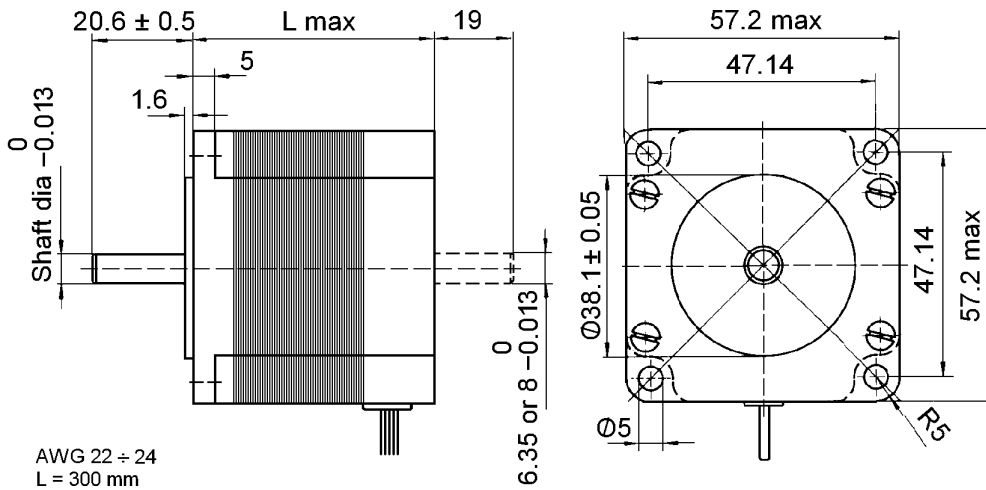
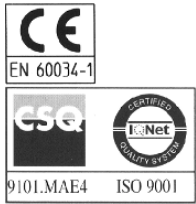

AWG 22 ÷ 24
L = 300 mm

Specifications	HS200 2216				HS200 2221			HS200 2231	
	0100 AX08	0210 AX08	0100 BX08	0210 BX08	0100 AX08	0210 AX04	0300 AX08	0210 AX04	0300 AX08
step angle	1,8°	1,8°	1,8°	1,8°	1,8°	1,8°	1,8°	1,8°	1,8°
step angle accuracy	% 5	5	5	5	5	5	5	5	5
rated phase current	A 1	2,1	1	2,1	1	2,1	3	2,1	3
phase resistance	Ω 4,6	1	6,2	1,4	0,7	2	1,1	6,5	1,7
phase inductance	mH 4,6	2,1	8,8	3,9	0,9	6,5	1,7	125	163
holding torque unipolar *	Ncm 37	-	75	-	75	-	125	161	163
holding torque bipolar *	Ncm 47	47,5	98	98	98	161	163	6,8	6,8
detent torque	Ncm 2,1	2,1	4	4	4	6,8	6,8	340	340
rotor inertia	g cm ² 77	77	220	220	220	340	340	1,0	1,0
mass	Kg 0,5	0,5	0,7	0,7	0,7	1,0	1,0	78,5	78,5
max. length	mm 41	41	55	55	55	78,5	78,5	8	8
shaft dia	mm 6,35	6,35	6,35	6,35	6,35	8	8	75	75
max. applicable voltage	V 75	75	75	75	75	75	75	B	B
insulation class	B	B	B	B	B	B	B	B	B

* two phases "ON"

HS200 2216 0100 AX08

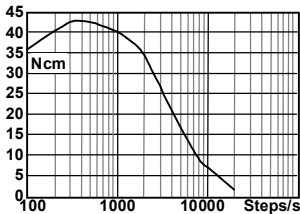

HS200 2216 0210 AX04

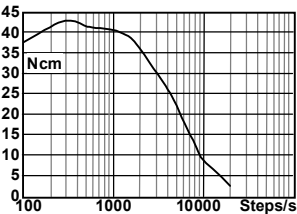

HS200 2221 0100 AX08

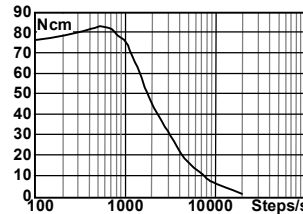

HS200 2221 0210 AX04

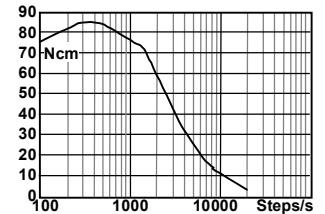

DRIVE: BIP.CHOP. PAR., 36 V - 1.4 A/PH

DRIVE: BIP.CHOP. PAR., 36 V - 2.1 A/PH

DRIVE: BIP.CHOP. PAR., 36 V - 1.4 A/PH

DRIVE: BIP.CHOP., 2.1 A/PH

HS200 2221 0300 AX08

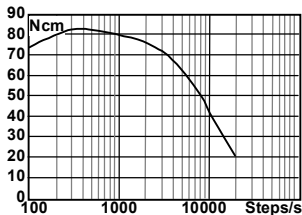

HS200 2231 0210 AX04

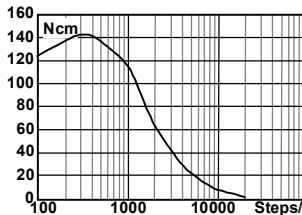

HS200 2231 0300 AX08

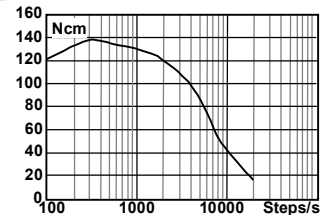

DRIVE: BIP.CHOP. PAR., 60 V - 4.2 A/PH

DRIVE: BIP.CHOP., 36 V - 2.1 A/PH

DRIVE: BIP.CHOP. PAR., 60 V - 4.2 A/PH

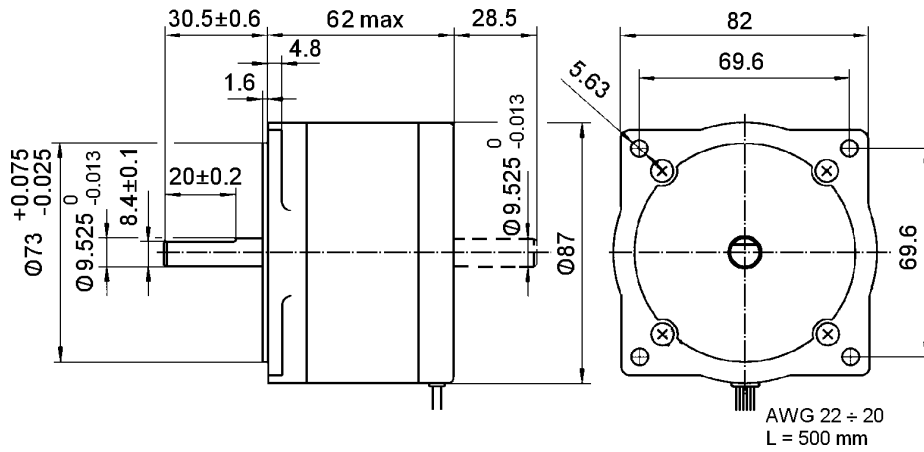
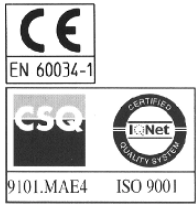

Specifications

HY200 3424

		0130 AX08	0170 AX08	0310 AX08	0470 AX08
		0130 BX08	0170 BX08	0310 BX08	0470 BX08
step angle		1,8°	1,8°	1,8°	1,8°
step angle accuracy	%	5	5	5	5
rated phase current	A	1,3	1,7	3,1	4,7
phase resistance	Ω	4,5	1,8	0,90	0,41
phase inductance	mH	16,9	5,3	2,9	1,5
holding torque unipolar *	Ncm	141	116	141	150
holding torque bipolar *	Ncm	182	150	182	193
detent torque	Ncm	12	12	12	12
rotor inertia	g cm ²	640	640	640	640
mass	Kg	1,3	1,3	1,3	1,3
max. applicable voltage	V	90	90	90	90
insulation class		B	B	B	B

* two phases "ON"

HY200 3424 0130 AX08

HY200 3424 0170 AX08

HY200 3424 0310 AX08

HY200 3424 0470 AX08

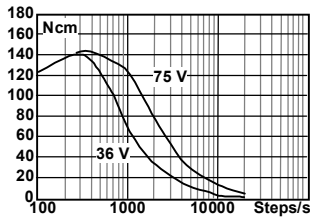

DRIVE: BIP.CHOP. PAR., 1.8 A/PH

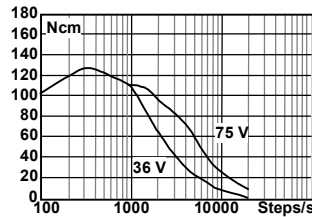

DRIVE: BIP.CHOP. PAR., 2.4 A/PH

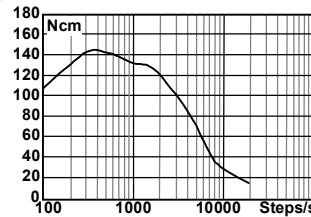

DRIVE: BIP.CHOP. PAR., 75 V - 4.4 A/PH

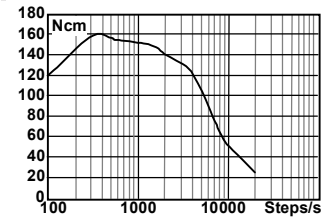

DRIVE: BIP.CHOP., 75 V - 6.7 A/PH

HY200 3424P, HY200 3437 and HY200 3437P are obsolete and replaced by the HN34xx series. Available only on request.

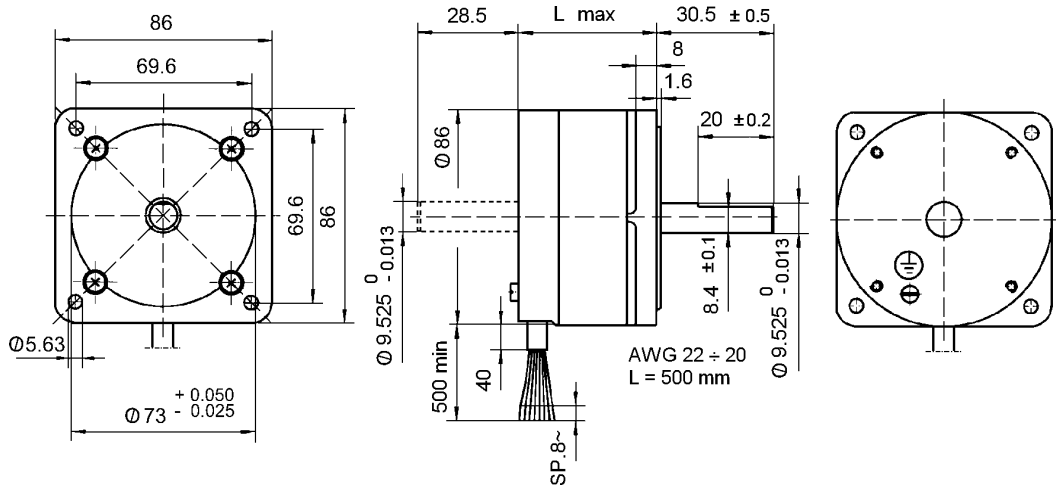
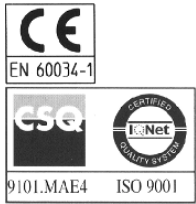

Specifications	HN200 3426			HN200 3438		HN200 3451	
	0140 AX08 0140 BX08	0280 AX08 0280 BX08	0430 AX08 0430 BX08	0280 AX08 0280 BX08	0430 AX08 0430 BX08	0350 AX08 0350 BX08	0640 AX08 0640 BX08
step angle	1,8°	1,8°	1,8°	1,8°	1,8°	1,8°	1,8°
step angle accuracy	% 5	5	5	5	5	5	5
rated phase current	A 1.4	2,8	4,3	2,8	4,3	3,5	6,4
phase resistance	Ω 5	1,3	0,55	1,7	0,75	1,5	0,5
phase inductance	mH 21	5,1	2,1	7,7	3,5	8,5	2,5
holding torque unipolar *	Ncm 230	230	230	380	380	620	620
holding torque bipolar *	Ncm 280	280	280	480	480	760	760
detent torque	Ncm 8,5	8,5	8,5	13	13	23	23
rotor inertia	g cm ² 660	660	660	1200	1200	1800	1800
theoretical acceleration	rad/s ² 42000	42000	42000	40000	40000	42000	42000
mass	Kg 1,6	1,6	1,6	2,4	2,4	3,6	3,6
max. applicable voltage	V 90	90	90	90	90	140	140
length	mm 67	67	67	94	94	125	125
insulation class	B	B	B	B	B	B	B
protection class	IP 55 (1)	IP 55 (1)	IP 55 (1)	IP 55 (1)	IP 55 (1)	IP 55 (1)	IP 55 (1)

* two phases "ON"
(1) for versions SX - EX - LX

HN200 3426 0140 AX08

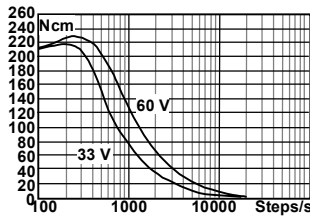

DRIVE: BIP.CHOP. PAR., 2 A/PH

HN200 3426 0280 AX08

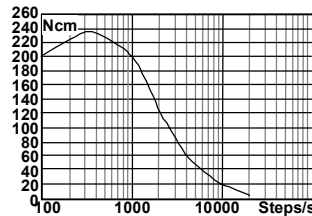

DRIVE: BIP.CHOP. PAR., 60 V - 4 A/PH

HN200 3426 0430 AX08

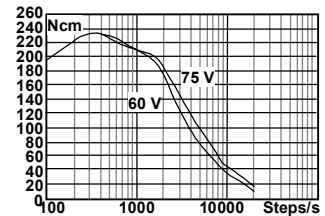

DRIVE: BIP.CHOP. PAR., 6 A/PH

HN200 3438 0280 AX08

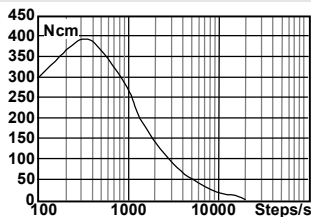

DRIVE: BIP.CHOP. PAR., 60 V - 4 A/PH

HN200 3438 0430 AX08

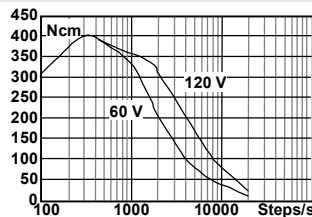

DRIVE: BIP.CHOP. PAR., 6 A/PH

HN200 3451 0350 AX08

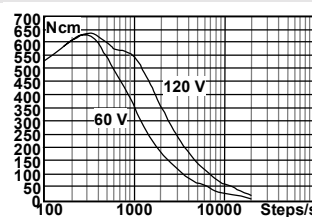

DRIVE: BIP.CHOP. PAR., 5 A/PH

HN200 3451 0640 AX08

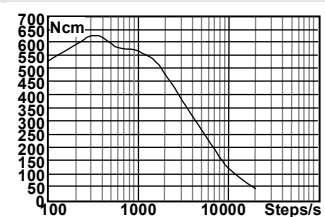

DRIVE: BIP.CHOP. PAR., 120 V - 9 A/PH

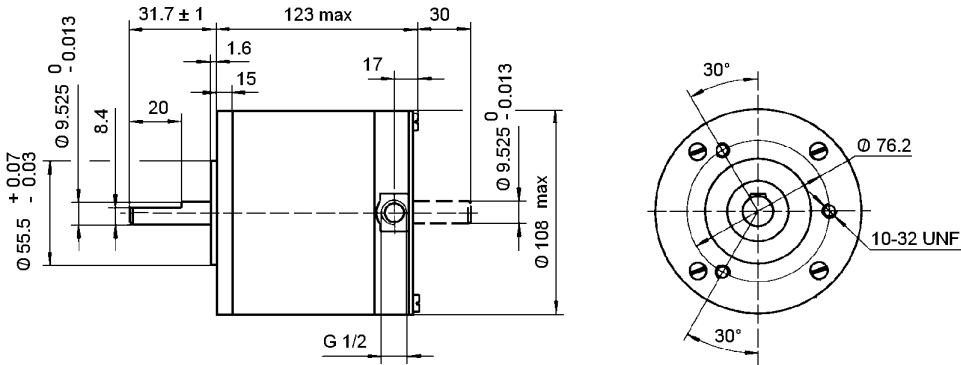
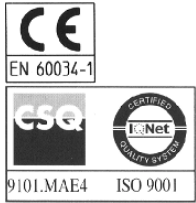

Specifications

	HY200 4247	
	0310 AX08 0310 BX08	0800 AX08 0800 BX08
step angle	1,8°	1,8°
step angle accuracy	%	
rated phase current	3,1	8,0
phase resistance	1,3	0,20
phase inductance	6,8	1,5
holding torque unipolar *	477	488
holding torque bipolar *	580	597
detent torque	41	41
rotor inertia	2800	2800
mass	4,6	4,6
max. length	123	123
max. applicable voltage	140	140
insulation class	B	B

* two phases "ON"

HY200 4247 0310 AX08

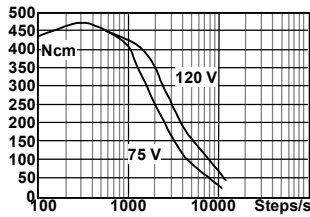

DRIVE: BIP.CHOP. PAR., 4.5 A/PH

HY200 4247 0800 AX08

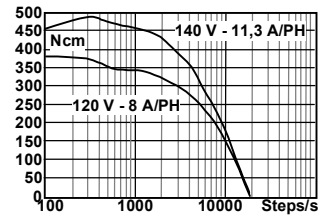

DRIVE: BIP.CHOP. PAR.

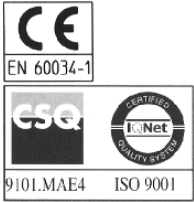

HY 200 4266

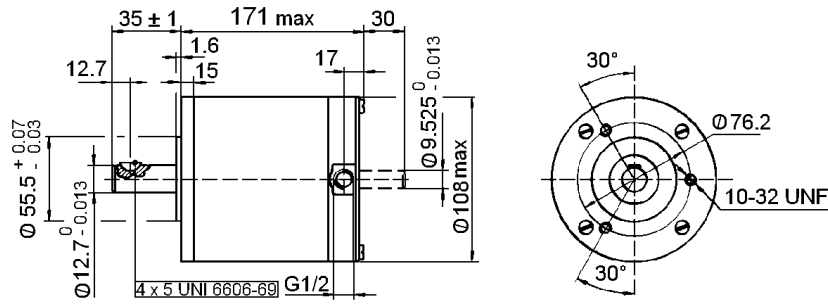

HY 200 4270

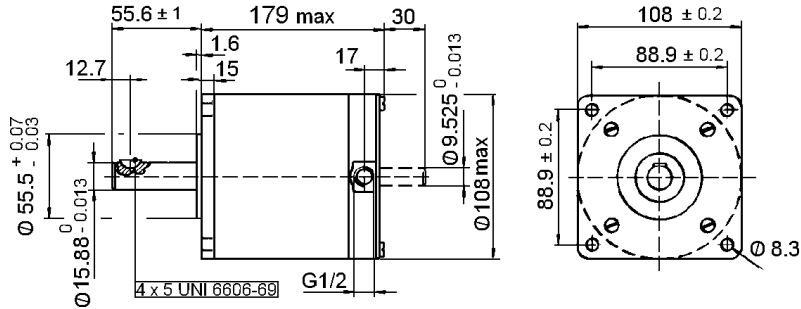

Specifications

	HY200 4266/4270			
	0340 AX08 0340 BX08	0710 AX08 0710 BX08	0900 AX08 0900 BX08	
step angle	1,8°	1,8°	1,8°	
step angle accuracy	5	5	5	
rated phase current	3,4 A	7,1	9,0	
phase resistance	1,1 Ω	0,30	0,34	
phase inductance	6,3 mH	2,0	2,7	
holding torque unipolar *	798 Ncm	830	1024	
holding torque bipolar *	990 Ncm	1030	1270	
detent torque	70 Ncm	70	70	
rotor inertia	5500 g cm ²	5500	5500	
mass	7,3 Kg	7,3	7,3	
max. applicable voltage	140 V	140	140	
insulation class	B	B	B	

* two phases "ON"

HY200 4266/4270 0340 AX08

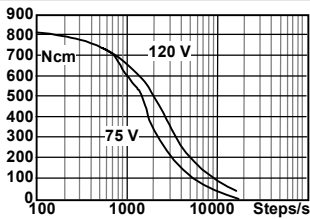

DRIVE: BIP.CHOP. PAR., 4,8 A/PH

HY200 4266/4270 0710 AX08

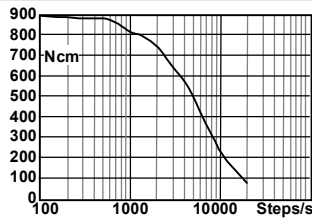

DRIVE: BIP.CHOP. PAR., 140 V - 10 A/PH

HY200 4266/4270 0900 AX08

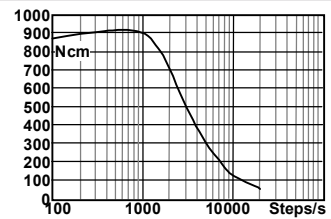

DRIVE: BIP.CHOP. PAR., 140 V - 12 A/PH

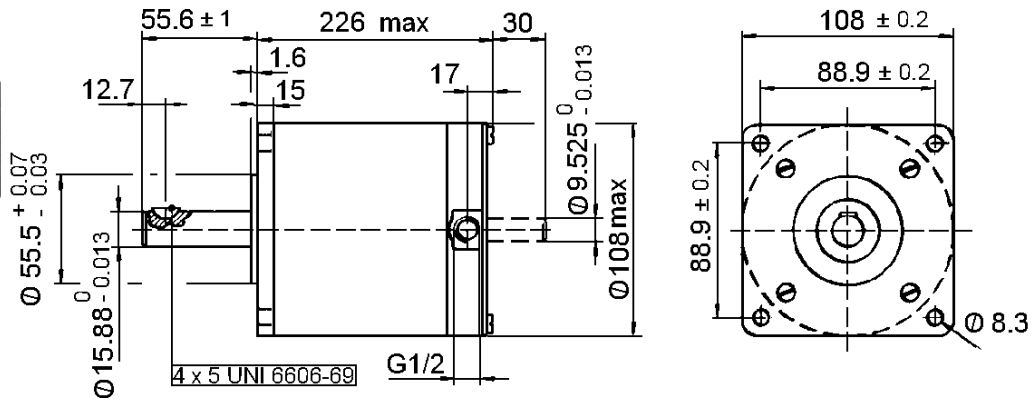

Specifications

HY200 4288

0890 AX08
0890 BX08

step angle		1,8°
step angle accuracy	%	5
rated phase current	A	8,9
phase resistance	Ω	0,31
phase inductance	mH	2,3
holding torque unipolar *	Ncm	1140
holding torque bipolar *	Ncm	1425
detent torque	Ncm	65
rotor inertia	g cm ²	8300
mass	Kg	10,5
max. applicable voltage	V	140
insulation class		B

* two phases "ON"

HY200 4288 0890 AX08

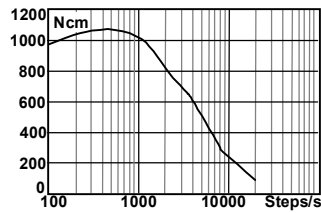

DRIVE: BIP.CHOP. PAR., 140 V - 12 A/PH

HY100 1613

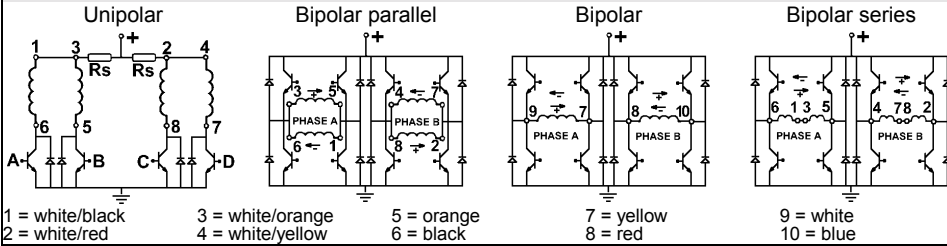

HY200 1607

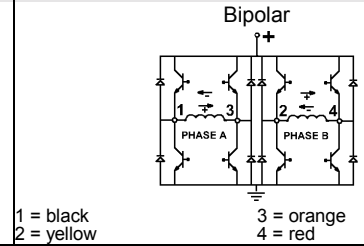

HY200 1713

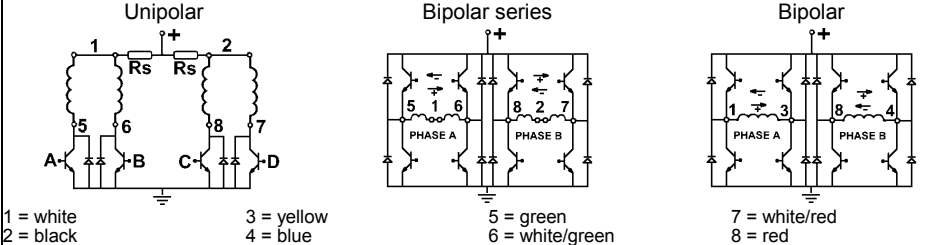

HY200 1717 / 1718

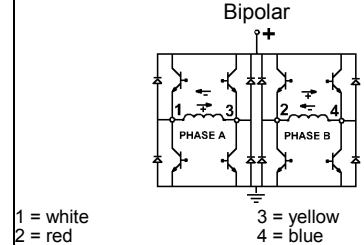

HY200 2215

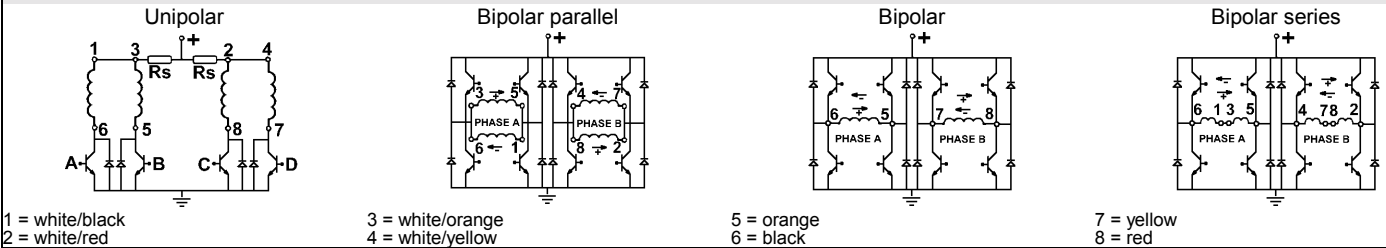

HY200 2220

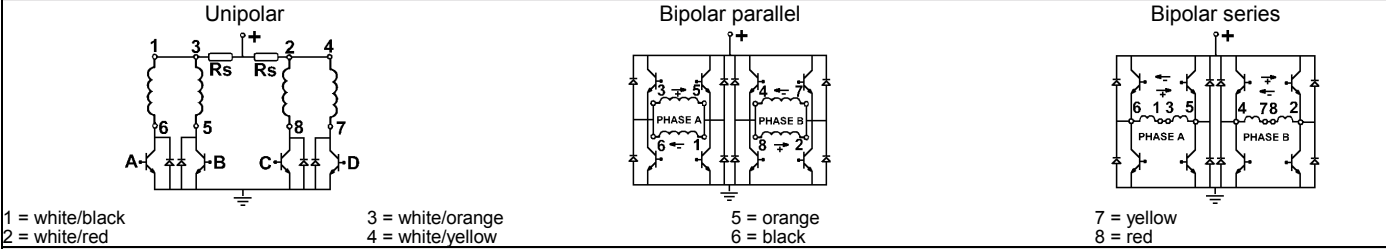

HY200 2226

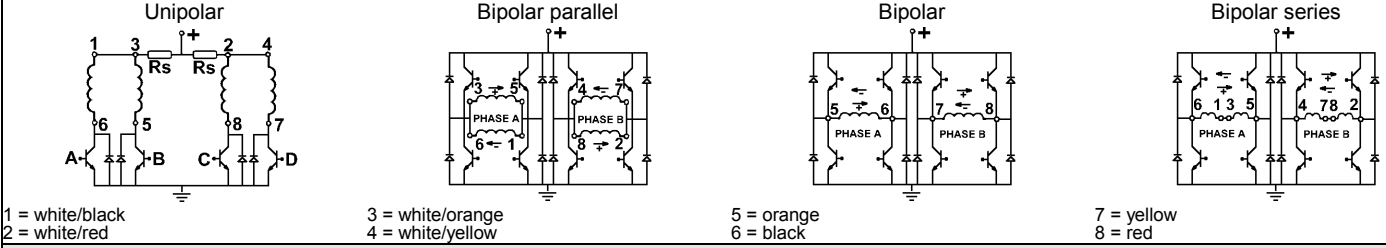

HY200 2240

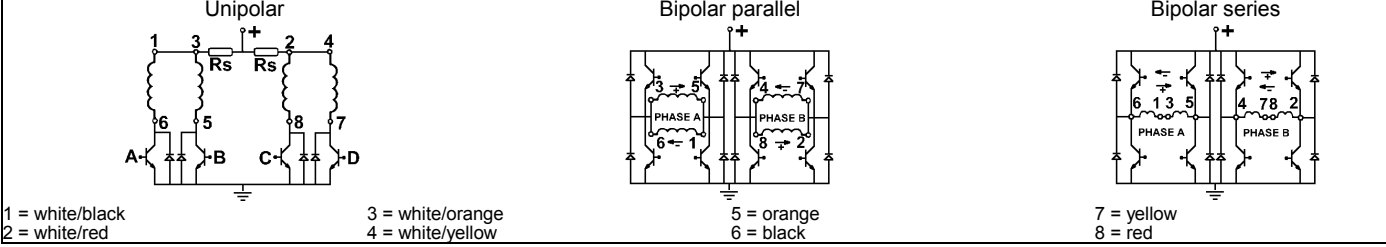

HS200 2216

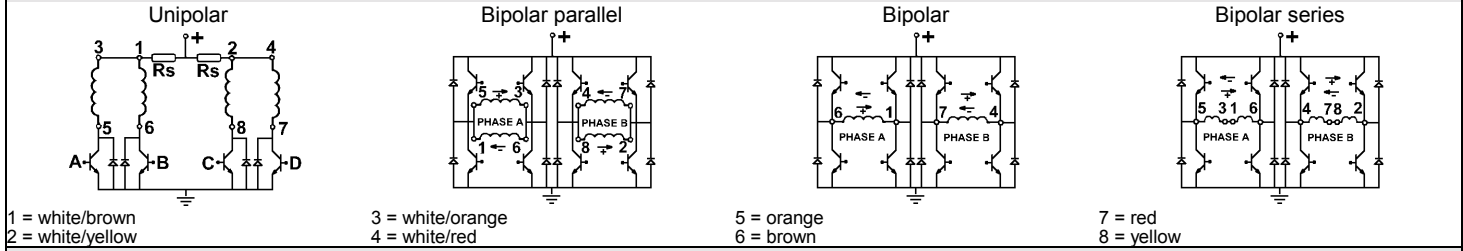

HS200 2221

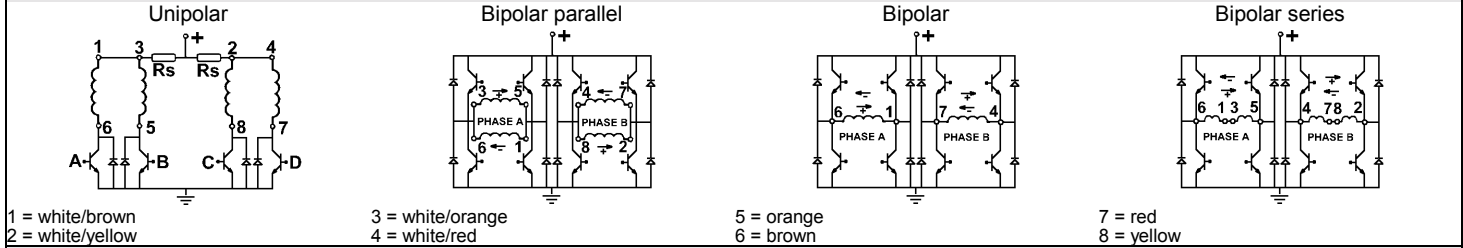

HS200 2231

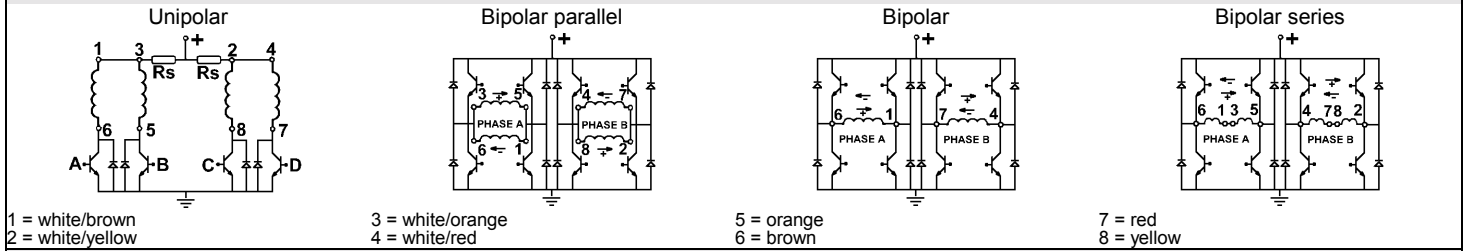

HY200 3424

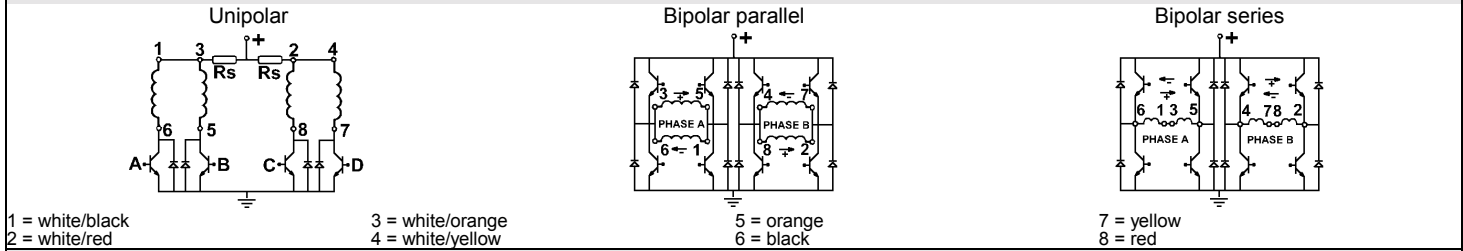

HN200 34xx

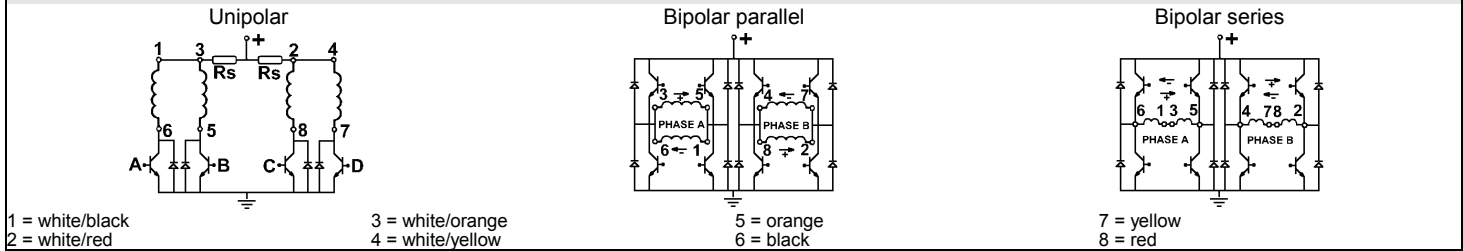

HY200 4247

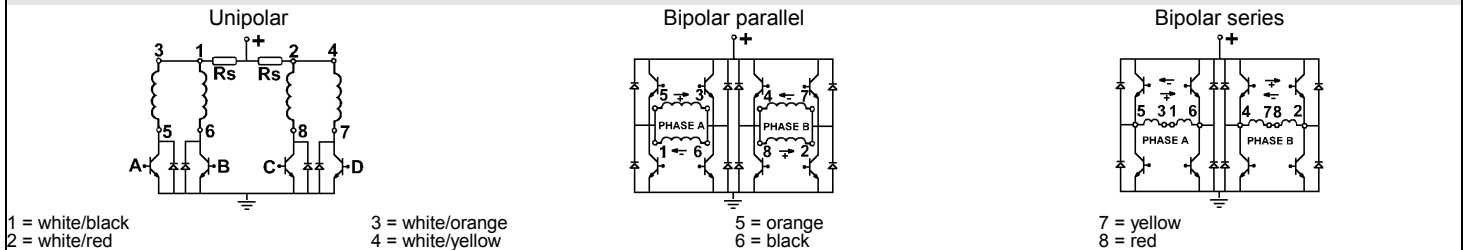

HY200 4266 / 4270

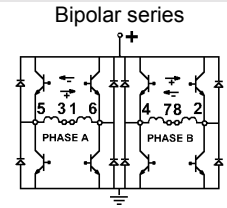
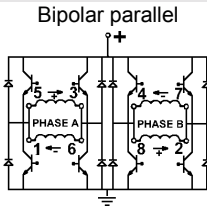
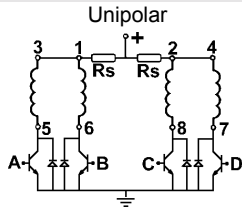

1 = white/black
2 = white/red

3 = white/orange
4 = white/yellow

5 = orange
6 = black

7 = yellow
8 = red

HY200 4288

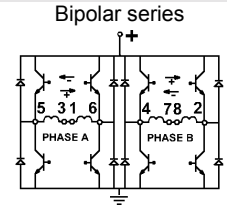
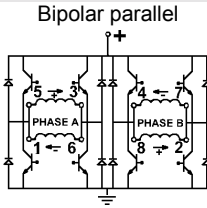
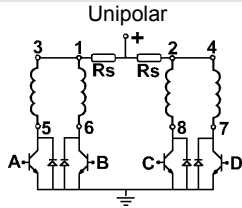

1 = white/black
2 = white/red

3 = white/orange
4 = white/yellow

5 = orange
6 = black

7 = yellow
8 = red

Drive Sequence

UNIPOLAR

STEP	HALF STEP PHASES			
	A	B	C	D
1	+	0	0	+
2	+	0	0	0
3	+	0	+	0
4	0	0	+	0
5	0	+	+	0
6	0	+	0	0
7	0	+	0	+
8	0	0	0	+
1	+	0	0	+

STEP	FULL STEP PHASES			
	A	B	C	D
1	+	0	0	+
2	+	0	+	0
3	0	+	+	0
4	0	+	0	+
1	+	0	0	+

BIPOLAR

STEP	HALF STEP PHASES	
	A	B
1	+	+
2	0	+
3	-	+
4	-	0
5	-	-
6	0	-
7	+	-
8	+	0
1	+	+

STEP	FULL STEP PHASES	
	A	B
1	+	-
2	+	+
3	-	+
4	-	-
1	+	-

Clockwise rotation with motor seen from the flange side

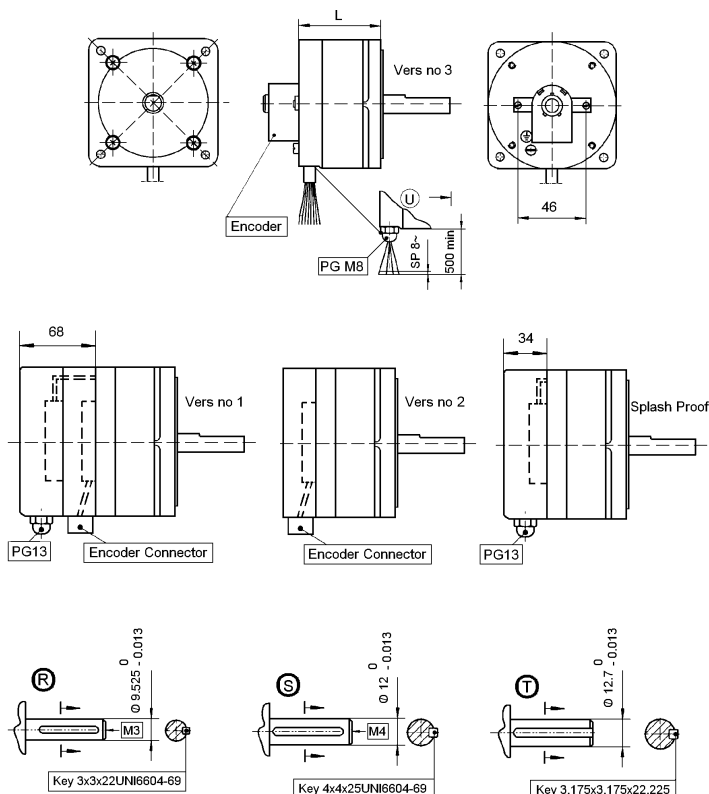

HN200 34xx

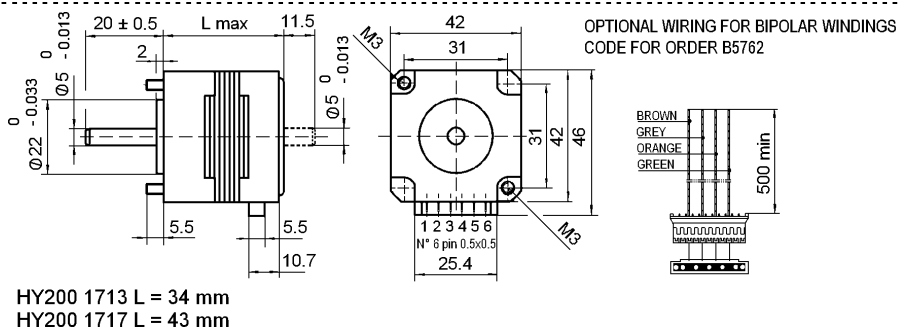

HY200 17xx

FLANGE WITH SCREWED HOLES
SCREWING DEPTH 4.5 mm

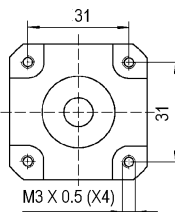

HY200 1713 0100 BS04

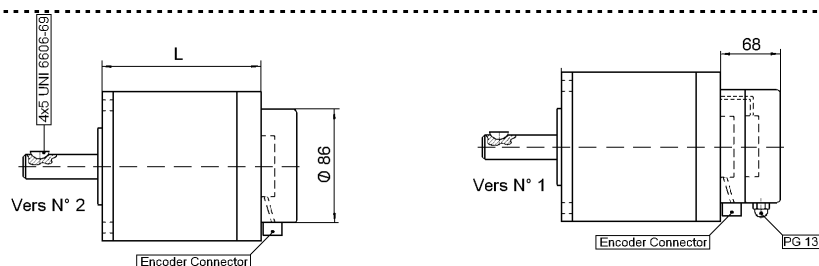

HY200 42xx